

615

I



Prima di procedere al fissaggio della tasca sull'albero, assicurarsi che i due fori filettati (fig. 1 rif ①) si trovino in corrispondenza del lato inferiore dell'asta (profilo in gomma antiurto).



Sequenza di montaggio:

- Montare la tasca sull'albero utilizzando la viteria in dotazione (fig. 1 rif. ②). Assicurarsi che la tasca sia in battuta sull'albero come indicato in figura 2.
- Inserire l'asta sulla tasca e bloccarla con le due viti a corredo (fig. 1 rif. ③).
- Montare la copertura dell'asta utilizzando la vite in dotazione (fig. 1 rif. ④).



Al fine di agevolare il fissaggio della tasca si consiglia di ingrassare l'albero.

GB



Before assembling the pocket on the shaft, ensure that the two threaded holes (fig. 1 ref. ①) are in a position corresponding with the lower side of the beam (rubber protection strip).



Mounting sequence:

- Assemble the pocket on the shaft using the provided set of screws (fig. 1 ref. ②). Certify that the pocket encounters the shaft as indicated in fig. 2.
- Insert the beam on the pocket and block it with the two provided screws (fig. 1 ref. ③).
- Mount the beam cover with the provided screws (fig. 1 ref. ④).



In order to facilitate the assembly of the pocket it is recommended to grease the shaft.

F



Avant de procéder à la fixation de la bride sur l'arbre, s'assurer que les deux trous taraudés (fig. 1 réf. ①) se trouvent en correspondance du côté inférieur de la lisse (bande de caoutchouc anti-choc).



Séquence de montage:

- monter la bride sur l'arbre en utilisant la visserie fournie (fig. 1 rif. ②). S'assurer que la bride soit en butée sur l'arbre comme indiqué dans la figure 2.
- insérer la lisse sur la bride et la bloquer avec les deux vis fournies (fig. 1 réf. ③).
- monter le capot de la lisse en utilisant la vis fournie (fig. 1 réf. ④).



Afin de faciliter la fixation de la bride, il est conseillé de graisser l'arbre.

E



Antes fijar la brida en el eje, asegurarse que los dos agujeros roscados (fig. 1 rif. ①) se encuentren en correspondencia del lado inferior de la barra (perfil en goma antichoque).



Secuencia de montaje:

- Ensamblar la brida en el eje utilizando los tornillos en dotación (fig. 1 rif. ②). Asegurarse que la brida esté insertada hasta el final del eje como indicado en la figura 2.
- Insertar la barra sobre la brida y bloquearla utilizando los dos tornillos suministrados (fig. 1 rif. ③).
- Montar la cobertura de la barra utilizando el tornillo en dotación (rif. 1 rif. ④).



Para facilitar la fijación de la brida se recomienda engrasar el eje.

D



Vor der Montage der Balkenbefestigung an der Welle ist es sicherzugehen, dass die zwei Gewindebohrungen (Abb. 1 Ref. ①) mit der unteren Seite (Gummiprofil) des Balkenprofils übereinstimmen.



Montagefolge:

- Die Balkenbefestigung mittels der mitgelieferten Schrauben an der Welle montieren (Abb. 1 Ref. ①). Sichergehen, dass die Balkenbefestigung bis zum Wellenanschlag geht (siehe Abb. 2).
- Den Balken in der Balkenbefestigung einsetzen und ihn mit den mitgelieferten Schrauben fixieren (Abb. 1 Ref. ③).
- Die Abdeckung mittels der mitgelieferten Schraube (Abb. 1 Ref. ④) montieren.



Um die Montage der Balkenbefestigung zu erleichtern empfehlen wir, die Welle zu schmieren.

NL



Vooraleer verder te gaan met het bevestigen van de fixeerplaat op de as, moet men zich ervan vergewissen dat de 2 met schroefdraad afgezette gaten (fig.1 rif. ①) zich bevinden in overeenstemming met het onderste deel van de stang (profiel in antichoc rubber).



Montage sequentie:

- De fixeerplaat op de mast monteren door gebruik te maken van de bijgevoegde schroeven (fig.1 rif. ②). Zich ervan vergewissen dat de fixeerplaat op de mast gefixeerd wordt zoals op fig. 2 aangeduid (beide delen moeten in contact zijn).
- de stang in de fixeerplaat schuiven en haar blokkeren met de 2 schroeven in de uitzet (fig.1 rif. ③).
- Het beschermingsdeel van de stang monteren door gebruik te maken van de bijgevoegde schroeven (fig. 1 rif. ④).



Om het vastmaken van de fixeerplaat te vereenvoudigen, is het aan te raden de mast te olien.

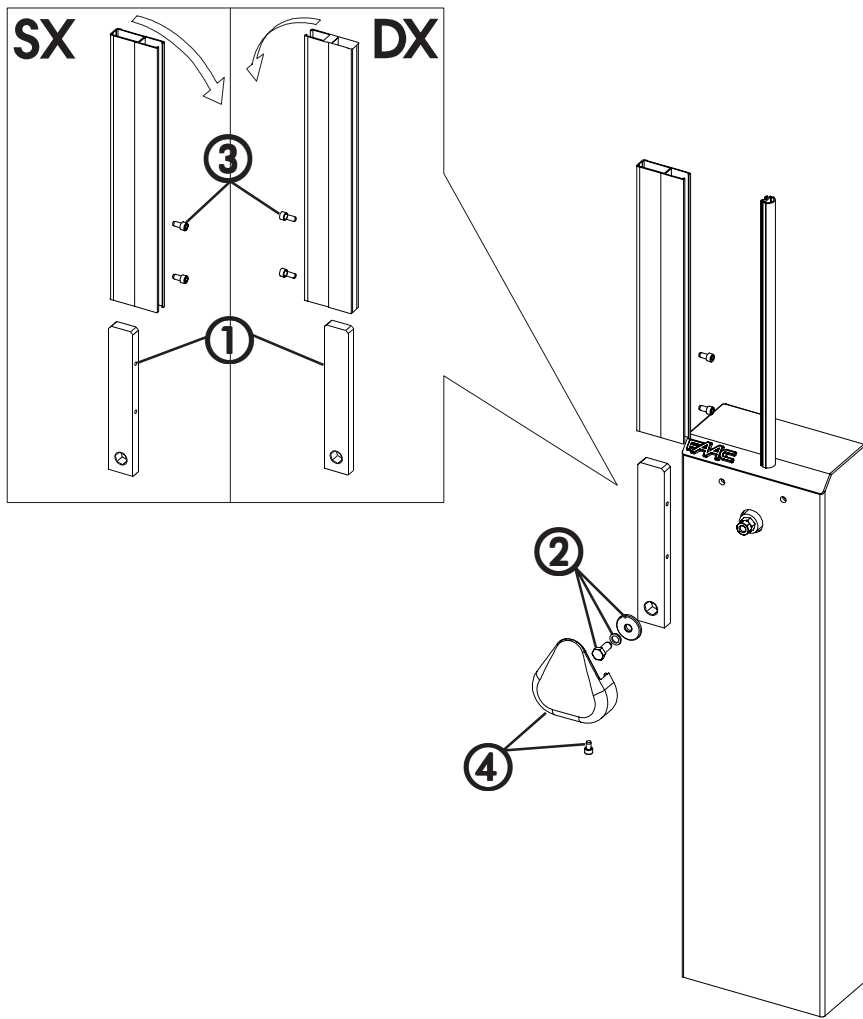

fig.1

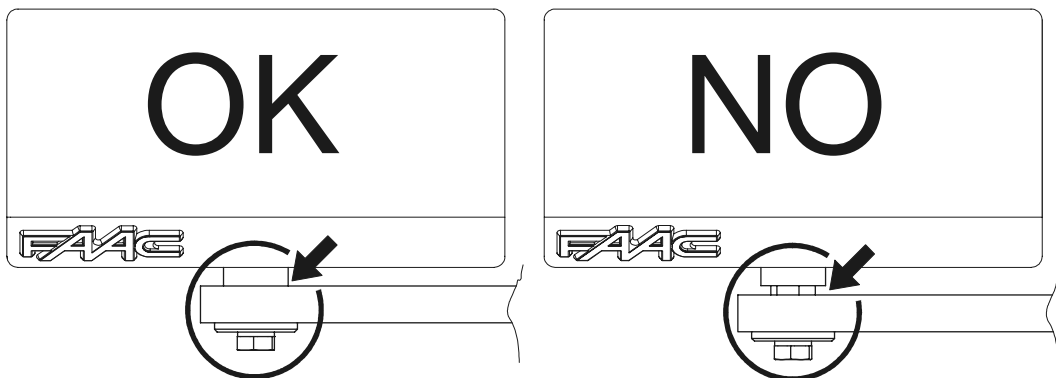

fig.2